

SURFACE-MOUNTED
Vertical

CP0016V
Polypropylene
White finish



CP0016VCSB
Polypropylene /Stainless steel Matte
black finish



CP0016VCS
Polypropylene /Stainless steel
Satin finish

General Description

- Surface-mounted baby changing stations made of bacterial-resistant polypropylene and with stainless steel AISI 304 exterior (CP0016VCS and CP0016VCSB).
- BabyMedi® changing stations offer a very high level of safety and cleanliness being the ideal solution for public spaces such as, shopping centers, airports, public buildings, childcare centres, etc. Models suitable for high traffic facilities with high strength and durability.
- Their trendy and stylish design, allow these baby changing stations to blend into any space perfectly.
- Biocote® antimicrobial additive, based on ion silver technology, is embedded into its own surface, promoting an easy cleaning and reducing the growth of odor causing and staining microbes.
- BabyMedi® baby changing stations are supplied (inside the packing box) with child protection straps made of nylon.
- A pair of bag hooks (one at the right side and the other one at the left) help to keep personal belongings close and at hand.
- BabyMedi® units fully comply with the EN 12221-1 and EN 12221-2 standards that require baby changing stations be able to support a 50 Kg static load test during one hour.

Components and materials

- **CP0016V:** surface-mounted baby changing station made of polypropylene in white finish.
- **CP0016V-I:** surface-mounted baby changing station made of polypropylene in white finish with ionizer.
- **CP0016VCSB:** surface-mounted baby changing station made of polypropylene and with a stainless steel AISI 304 exterior, in matte black finish.
- **CP0016VCSB-I:** surface-mounted baby changing station made of polypropylene and with a stainless steel AISI 304 exterior, in matte black finish with ionizer.
- **CP0016VCS:** surface-mounted baby changing station made of polypropylene and with a stainless steel AISI 304 exterior, in satin finish.
- **CP0016VCS-I:** surface-mounted baby changing station made of polypropylene and with a stainless steel AISI 304 exterior, in satin finish with ionizer.
- **BED:** with a 1,900 cm² contoured changing surface area is made of polypropylene in white finish with Biocote® antimicrobial additive embedded into its own surface, promoting an easy cleaning and reducing the growth of odor causing and staining microbes.
- **LINER DISPENSER:** with lock is made of polypropylene and holds approximately 80 bed liners, minimizing operator refills and discouraging potential vandalism.
- **OPEN/CLOSE MECHANISM:** concealed from the user's view, it consists of a pair of reinforced hinges and a pneumatic cylinder, ensuring high durability and a smooth opening and closing of the baby changing station.

Technical Specifications

Dimensions	<i>L:550 x W:100 (closed)/ 890 (open) x H:480 mm</i>
Weight (empty)	<i>13.4 Kg (CP0016V) 17.6 Kg (CP0016VCS-B)</i>
Liner dispenser capacity	<i>80 units</i>
Recommended installation height	<i>800 mm at lowest point</i>
Recommended installation height (handicapped)	<i>700 mm at lowest point</i>

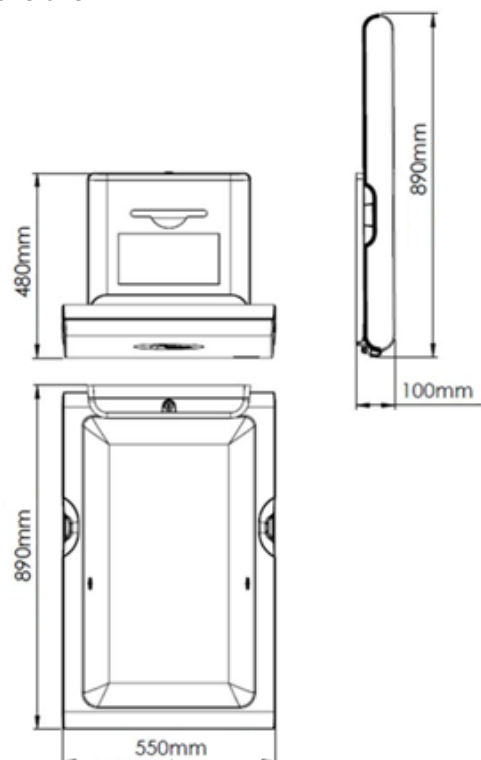
Dimensions

Dimensions ±4%

Components and materials (continuation)

- **MOUNTING CHASSIS:** made of steel with a cataphoresis treatment. The corresponding mounting hardware is supplied, making very easy the installation of the unit to the wall.
- **FRONTAL CHASSIS:** (CP0016VCS and CP0016VCSB) made of one-piece AISI 304 stainless steel, 0.8 mm thick, fixed to the bottom of the bed by means of 4 bolts and 4 nuts, always concealed from the user's view, without joints or edges to ensure the user's safety, a better cleaning and an easy blending with other satin-finish accessories in the washroom.

OPERATION

Open the BabyMedi® baby changing station. Place the baby in the centre of the bed and change your baby's diapers. Close the BabyMedi® station.

Under no circumstance should the baby be left unattended at any time on top of the baby changing station in order to avoid injury from falling or slipping.

Type 1 baby changing station with the purpose to be used from the children birth up to the age of 12 months and up to a weight of 11 Kg, in accordance with the manufacturer's instructions for use.

MOUNTING

Fix the mounting chassis on the wall using the provided screws through the mounting chassis holes (points indicated by an "S" in the figure below) and **always following, step by step, the detailed instructions contained in the "Installation and safety instructions manual"**, provided with the unit.

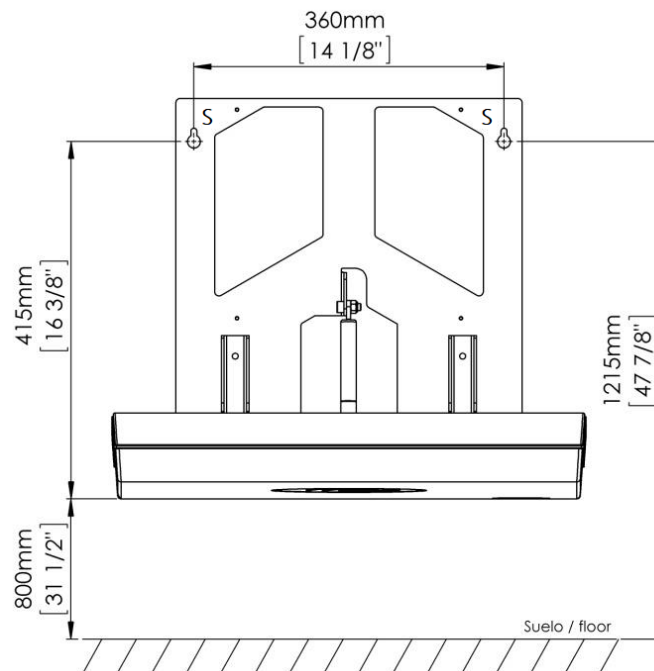

Warning: to ensure that the unit works properly and safely it must be installed according to the Mediclinics instructions supplied with the BabyMedi®.

The fixing systems supplied with this changing station are not suitable for installation on plasterboard or hollow walls. In order to install the unit on this type of wall, fastening anchors and tools specific for plasterboard or hollow walls must be used.

Due to the problems posed by installations on this type of walls, with regard to fixing, it is recommended that the installation is carried out by technicians specialized in installations on this type of walls. **Mediclinics is not responsible for the installation of its changing stations on plasterboard or hollow walls.**

CERTIFICATIONS AND HOMOLOGATIONS



Mediclinics, S.A., reserves the right to make changes and/or modifications to the products and their specifications without prior notice.
Reviewed 10-24 © mediclinics S.A.

